

# Accessories

Safety Head/Rupture Discs  
Pressure Gauges/Snubbers  
Thermocouples



## Accessories Components:

Parker Autoclave Engineers offers a complete selection of accessories to complete your system requirements.

**Thermocouples** and **Thermowells** are used for monitoring and controlling temperatures in systems with operating pressures up to 60,000 psi (4137 bar).

**Safety Head/Rupture Disc** assemblies are used to protect systems and pressure vessels from over-pressure conditions. Rupture discs are available in various pressure ranges and material options suitable for the application.

**Pressure Gauges** are used to monitor and control pressure. P-Style pressure gauges are available in two sizes, 4-1/2" and 6" (114.3 mm and 152.4 mm), and ranges to 80,000 psi (5515 bar). Optional electrical contact faces for pressure control are used to set high and low limits. Gauges are standard panel mount or can be flush mounted with an optional flush mount kit. H-Style stainless steel case gauges with K-Monel bourdon tube are also offered for corrosive applications up to 30,000 psi (2068 bar)

**Gauge/Instrument Snubbers** provide superior pressure gauge protection without compromising instrument accuracy. Available with male and female Medium and High Pressure Cone and Thread connections in 1/4" and 3/8" sizes.



ENGINEERING YOUR SUCCESS.

# Pencil Type Thermocouples

Accessories - Pressures to 15,000 psi (1035 bar)

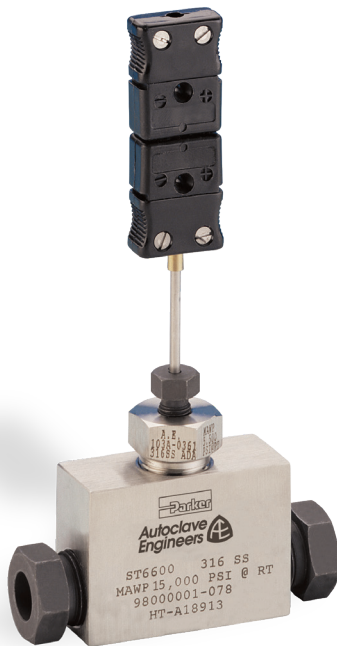

## Overview:

Thermocouples provide reliable temperature measurement within a system. The design permits installation of the element in direct contact with the fluid stream, thereby providing reliable temperature measurement. The quick-connector affords system flexibility. The thermocouple tip has a grounded-type junction.

## Materials:

Precision-molded plastic connectors have heavy duty, spring-loaded jack inserts for positive contact. The sheath is type 316 stainless steel with 316 SS ferrule and gland. We offer a choice of iron constantan (J) or chromel-alumel (K) type elements (please specify when ordering). Basic assembly includes 1/8" Parker Autoclave Engineers Speedbite connection with adapters for other connection sizes.

## Pressure/Temperature Ratings:

Ratings to 15,000 psi (1035 bar) maximum working pressure. Temperature rating based on connection style. Low pressure Speedbite connection not recommended below -100°F (-73°C) or above 650°F (343°C).

## Ordering Information:

Catalog order numbers in the table refer to the complete assembly. Add suffix "J" for iron constantan element or "K" for chromel-alumel. To order a basic thermocouple with plug/jack assembly and connection adapter but **WITHOUT** Through or Angle-Style Tee change last digit in order number to "0" and specify sheath length if different from standard 3.62" (91.94 mm) length.

Ordering examples: TP4400K 6" (152.4 mm) denotes basic thermocouple to fit into a 1/4" Parker Autoclave Engineers SpeedBite connection with chromel-alumel element and 6" (152.4 mm) sheath. TP 4401K denotes the above unit complete with through-type Tee assembly and standard 3.62" (91.94 mm) sheath.

## Thermocouple Specification Table

Calibration Type	Type of Thermocouples	Temperature Range	Comments
J	Iron (+) Constantan (-)	32 to 1400°F (0 to 760°C)	Reducing atmosphere recommended. Iron leg subject to oxidation to elevated temperatures.
K	Chromel (+) Alumel (-)	-328 to 2300°F (-200 to 1260°C)	Well suited for oxidizing atmosphere. Most commonly used calibration type.

## Through-Type

Catalog Number	Connection Type	Pressure Rating PSI (Bar)	Tubing Size inches (mm)	Dimensions - inches (mm)						Block Thickness
				A	B	C	D Typical	E	H	
TP2201*	W125 (1/8" LP)	15,000 (1035)	1/8 (3.18)	1.38 (35.05)	0.69 (17.53)	0.31 (7.87)	3.62 (91.95)	1.00 (25.40)	7.18 (182.37)	0.50 (12.70)
TP4401	SW250 (1/4" LP)	15,000 (1035)	1/4 (6.35)	1.75 (44.45)	0.88 (22.35)	0.44 (11.18)	3.62 (91.95)	1.19 (30.23)	7.25 (184.15)	0.62 (15.75)
TP6601	SW375 (3/8" LP)	15,000 (1035)	3/8 (9.52)	2.00 (50.80)	1.00 (25.40)	0.53 (13.46)	3.62 (91.95)	1.38 (35.05)	7.31 (185.67)	0.75 (19.05)
TP8801	SW500 (1/2" LP)	10,000 (690)	1/2 (12.70)	2.50 (63.50)	1.25 (31.75)	0.53 (13.46)	3.62 (91.95)	1.75 (44.45)	7.44 (188.98)	1.00 (25.40)

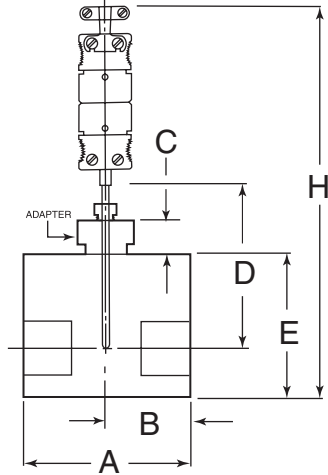

**Note:** All thermocouples are furnished complete with connection components unless otherwise specified.

\*Adapter not required. Tee is included in standard catalog number.

Maximum pressure rating is based on the lowest rating of any component. Actual working pressure may be determined by tubing pressure rating, if lower. Increased temperatures reduce mechanical strength. See Technical Brochure for pressure/temperature curves on most optional material.

Parker Autoclave Engineers stocks select products.

All dimensions for reference only and subject to change. For prompt service, Consult your local representative.

Low Pressure Speedbite Tee matching connection size selected is included with catalog number ending in "1". (ie; TP8801J)

## Angle-Type

Catalog Number	Connection Type	Pressure Rating PSI (Bar)	Tubing Size inches (mm)	Dimensions - inches (mm)						Block Thickness
				A	B	C	D Typical	E	H	
TP2202*	W125 (1/8" LP)	15,000 (1035)	1/8 (3.18)	1.00 (25.40)	0.75 (19.05)	0.31 (7.87)	3.62 (91.95)	1.38 (35.05)	7.62 (193.55)	0.50 (12.70)
TP4402	SW250 (1/4" LP)	15,000 (1035)	1/4 (6.35)	1.19 (30.23)	0.88 (22.35)	0.44 (11.18)	3.62 (91.95)	1.75 (44.45)	7.81 (198.37)	0.62 (15.75)
TP6602	SW375 (3/8" LP)	15,000 (1035)	3/8 (9.52)	1.38 (35.05)	1.00 (25.40)	0.53 (13.46)	3.62 (91.95)	2.00 (50.80)	7.94 (201.68)	0.75 (19.05)
TP8802	SW500 (1/2" LP)	10,000 (690)	1/2 (12.70)	1.75 (44.45)	1.25 (31.75)	0.53 (13.46)	3.62 (91.95)	2.50 (63.50)	8.19 (208.03)	1.00 (25.40)

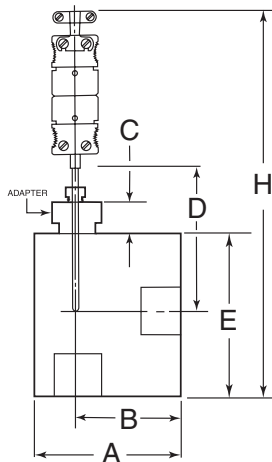

**Note:** All thermocouples are furnished complete with connection components unless otherwise specified.

\*Adapter not required. Tee is included in standard catalog number.

Maximum pressure rating is based on the lowest rating of any component. Actual working pressure may be determined by tubing pressure rating, if lower. Increased temperatures reduce mechanical strength. See Technical Brochure for pressure/temperature curves on most optional material.

Parker Autoclave Engineers stocks select products.

All dimensions for reference only and subject to change. For prompt service, Consult your local representative.

Low Pressure Speedbite Tee used in Angle configuration, matching connection size selected, is included with catalog number ending in "2". (ie; TP8802J)

# Sheath Type Thermocouples

Accessories - Pressures to 60,000 psi (4140 bar)



## Overview:

Thermocouples provide reliable temperature measurement within a system. Similar to low pressure thermocouples, this design also permits direct temperature monitoring at any point in a fluid system. The sheath type thermocouple features grounded junction and rapid response - 100 milliseconds or less at 63.3% of a step change.

## Materials:

Bodies are 15-5PH stainless steel. 316 SS sheath brazed into body with gold-nickel alloy brazing material. An aluminum terminal housing is threaded into the body for ready access to terminals. An o-ring seal provides moisture protection.

## Sheath Length:

Differs for each size connection for optimum tip contact with fluid stream. Sheath diameter is 1/16".

## Temperature Ratings:

Rating to 2,000°F (1093°C) at tip of thermocouple. (Refer to adjacent Pressure/Temperature chart for elevated temperatures.) Minimum operating temperature at the tip of the thermocouple: Type J = 0°F (-18°C), Type K = -328°F (200°C).

Maximum operating temperature for 15-5PH Body is 0° to 1000°F (-18° to 538°C)

Maximum operating temperature for 316 SS body is -328° to 1200°F (-200° to 650°C)

## Ordering Information:

To order thermocouples for use in standard Parker Autoclave Engineers tees or crosses, use order numbers listed in table (**fittings not included as standard**). For custom length sheaths, to extend through a vessel wall or cover, calculate sheath length from the detail drawings (Fig 1 & 2) on the following page:

1. Add vessel wall or cover thickness to the distance the sheath will extend into vessel.
2. When using a basic 1/4" Parker Autoclave connection, subtract dimension "M" for proper sheath length to order.
3. For all other connection sizes, add dimension "N" to measurement obtained in step 1.
4. Order a custom length sheath by adding desired length in inches as suffix to order number.

Standard collar and gland are cold worked 316 SS. When cold worked 316 SS collar and gland are used, the physical properties are permanently altered after use above 800°F (430°C). See Technical Brochure for full description.

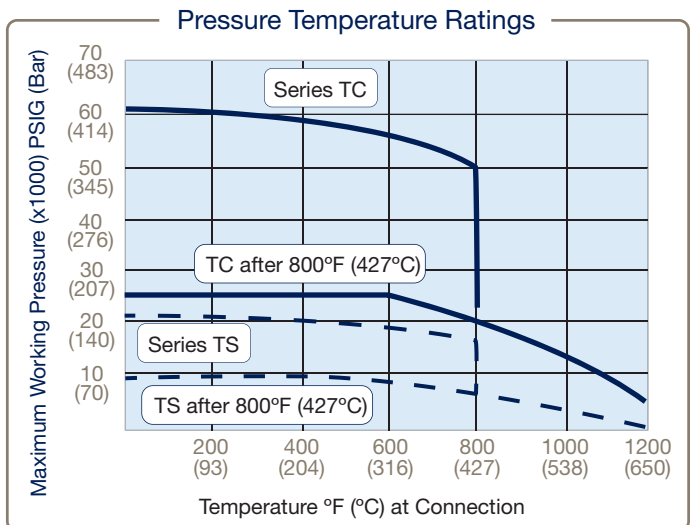

## Series TS Medium Pressure to 20,000 psi (1380)

Catalog Number	Fits Connection Type	Tubing Size inches (mm)	Element Type	Dimensions - inches (mm)				Fitting Pattern
				L	M	N	H	
TSJ4	SF250CX (1/4" MP)	1/4 (3.18)	iron constantan	0.28	0.50 (12.70)		5.78 (146.81)	Figure 1
TSK4			chromel-alumel	(7.11)				
TSJ6	SF375CX (3/8" MP)	3/8 (9.52)	iron constantan	1.19		0.19 (4.83)	6.67 (166.88)	Figure 2 (See Note)
TSK6			chromel-alumel	(30.23)				
TSJ9	SF562CX (9/16" MP)	9/16 (14.28)	iron constantan	1.19		0.13 (3.30)	6.50 (135.10)	
TSK9			chromel-alumel	(30.23)				
TSJ12	SF750CX (3/4" MP)	3/4 (19.05)	iron constantan	2.00		0.50 (12.70)	6.88 (174.75)	
TSK12			chromel-alumel	(50.80)				
TSJ16	SF1000CX (1" MP)	1 (25.4)	iron constantan	2.62		0.57 (14.48)	6.94 (176.28)	
TSK16			chromel-alumel	(66.55)				
TSJ24	SF1500CX (1-1/2" MP)	1-1/2 (38.10)	iron constantan	3.25		.688 (17.48)	7.06 (179.38)	
TSK24			chromel-alumel	(82.55)				

## Series TC High Pressure to 60,000 psi (4140)

TCJ4	F250C (1/4" HP)	1/4 (3.18)	iron constantan	0.38	0.50 (12.70)		5.88 (149.351)	Figure 1
TCK4			chromel-alumel	(9.65)				
TCJ6	F375C (3/8" HP)	3/8 (9.52)	iron constantan	1.38		0.32 (8.13)	6.69 (169.23)	Figure 2 (See Note)
TCK6			chromel-alumel	(35.05)				
TCJ9	F562C (9/16" HP)	9/16 (14.28)	iron constantan	1.62		0.25 (6.35)	6.627 (168.15)	
TCK9			chromel-alumel	(41.15)				

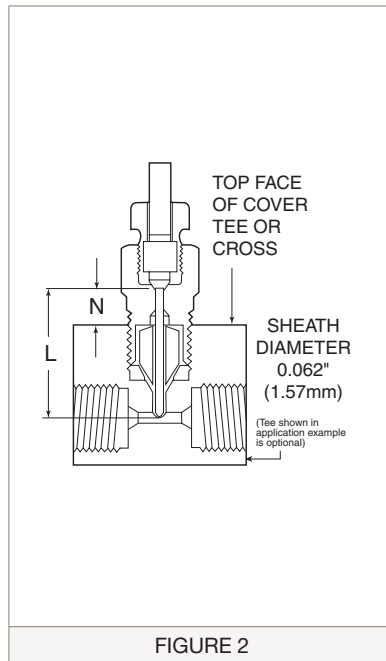
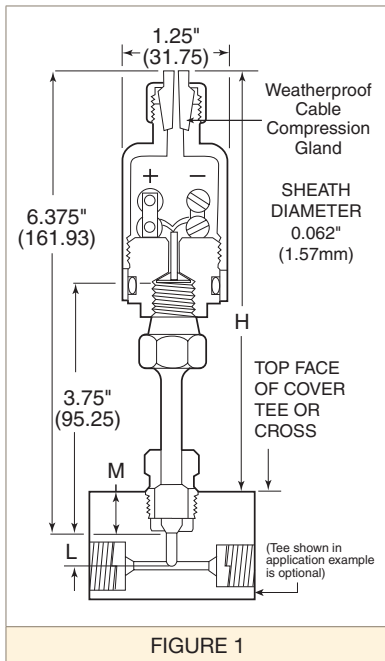

**Note:** All thermocouples are furnished complete with 1/4" Medium or High Pressure connection adapter to match tubing size selected. Union Tee or Cross sold separately.

TSJ24 and TSK24 do not extend past the wall of the bore.

\*Maximum pressure rating is based on the lowest rating of any component.

Actual working pressure may be determined by tubing pressure rating, if lower. All dimensions for reference only and subject to change.

For prompt service, Parker Autoclave Engineers stocks select products. Consult your local representative.

# Thermowells

Accessories - Pressures to 20,000 psi (1379 bar)

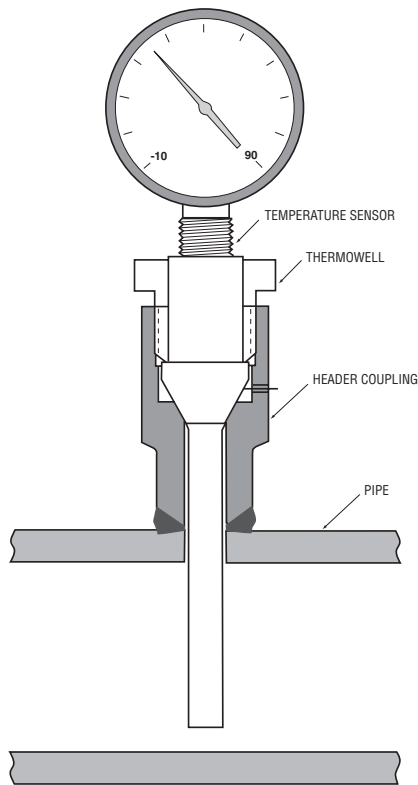

Typical Thermowell Assembly

## Overview:

Thermowells are used to provide isolation between a temperature sensor and the environment, such as liquid or gas. Thermowells protect the sensor from pressure, corrosion, abrasion or vibration caused by the process medium. Thermowells allow the temperature sensor to be removed and replaced without compromising either the ambient region or the process.

Parker Autoclave Engineers manufactures thermowells from solid bar stock to accommodate applications in the petrochemical, chemical, refining, power and other process industries.

Parker Autoclave Engineers manufactures 316SS thermowells capable of connecting to a 1" (SF1000CX) Parker Autoclave Engineers female medium pressure connection.

## Materials:

Care must be taken in determining the material used for the thermowell as well as other factors. Parker Autoclave Engineers offers design assistance that includes pressure, temperature and vibration effect of the fluids. This vibration can cause well stem failure.

Standard and special thermowell materials available:

- 316 Stainless Steel
- Hastelloy
- Inconel
- Connection gland included

To order Parker Autoclave Engineers thermowell assemblies, please refer to our order guide on next page to assist in determining your needs.

Contact your local representative or the factory for technical assistance and application suggestions.

## Ordering Information:

Catalog Number	Dimension "A" inches (mm)	Pressure Rating psi (bar)
TW02.75	2.75 (70.68)	20,000 (1379)
TW03.12	3.12 (79.25)	20,000 (1379)
TW03.86	3.86 (98.04)	20,000 (1379)
TW04.25	4.25 (107.95)	20,000 (1379)
TW04.50	4.50 (114.30)	20,000 (1379)
TW05.50	5.50 (139.70)	20,000 (1379)
TW05.75	5.75 (146.05)	20,000 (1379)
TW06.25	6.25 (158.75)	20,000 (1379)
TW07.00	7.00 (177.80)	20,000 (1379)
TW07.50	7.50 (190.50)	20,000 (1379)
TW010.00	10.00 (254.00)	20,000 (1379)
TW012.00	12.00 (304.80)	20,000 (1379)

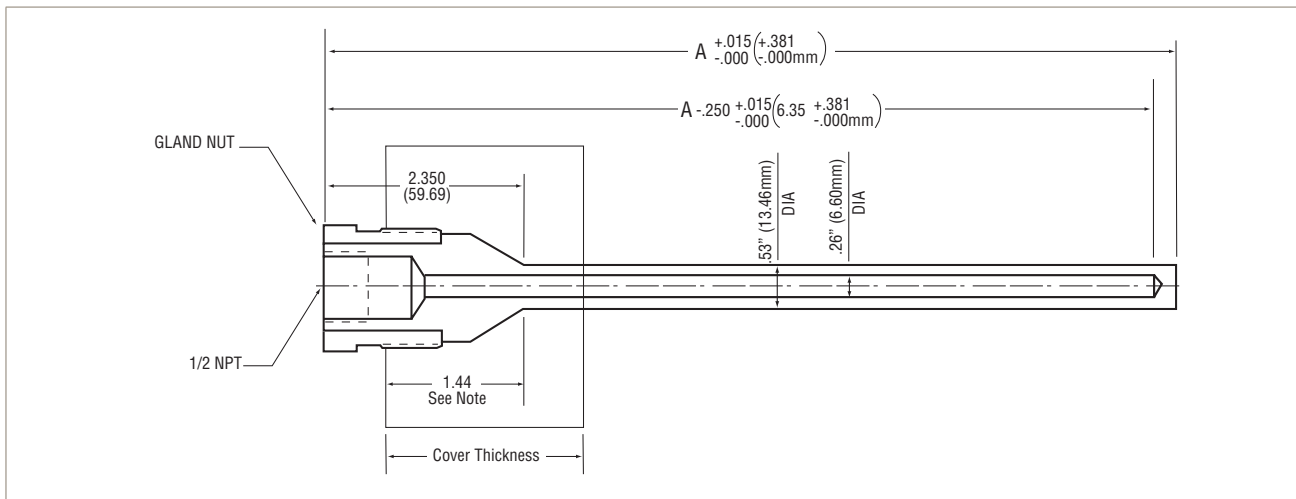

**Note:** Thermowells fit Autoclave's 1" medium pressure connection. (SF1000-CX). 1" connection insertion length is 1.44" (36.76).

# Universal Safety Heads

Accessories - Pressures to 110,000 psi (7584 bar)



## Safety Heads/Rupture Discs:

Safety Heads and Rupture Discs offer an economical and dependable relief port to guard against system over-pressure.

Parker Autoclave Engineers offers universal safety heads in three series compatible in orifice size and maximum pressure rating with Parker Autoclave Low Pressure, Medium Pressure and High Pressure valves, fittings and tubing.

Parker Autoclave Engineers Low Pressure Series SS: Parker Autoclave SpeedBite Single Ferrule compression tube connection, maximum rupture disc pressures to 15,000 psi (1034 bar).

Parker Autoclave Engineers Medium Pressure Series CSX: Parker Autoclave Medium-Pressure coned-and-threaded tube connection, maximum rupture disc pressures to 20,000 psi (1379 bar).

Parker Autoclave Engineers High Pressure Series CS: Parker Autoclave High Pressure coned-and-threaded tube connection, maximum rupture pressure to 110,000 psi (7584 bar).

The 3/16F style features a 3/16" blow-out diameter and a **FLAT** seat which can be ordered in pressure range from 200 to 27,000 psi (13.8 to 1862 bar).

The 1/4A style features a 1/4" blow-out diameter and an **ANGULAR** seat which can be ordered in pressures from 900 to 110,000 psi (62 to 7584 bar).

The 1/2F style features a 1/2" blow-out diameter and a **FLAT** seat which can be ordered in pressures from 500 to 10,000psi (35 to 690 bar).

## Material and Features:

- Non-rotating double-cone plug design avoids galling and scoring of safety head or connection during installation. Reduces likelihood of leakage.
- Interchangeable hold-down rings permit use of several different sizes and types of rupture discs in a single safety head. Accommodates discs with rupture pressures as low as 90 psi (6.2 bar) and ranging to 60,000 psi (4137 bar) and above.
- Installs in any standard Parker Autoclave Engineers coupling, elbow, cross or tee.
- Cold-worked Type 316 SS body hold down gland and plug, all series.
- Hold down rings are corrosion resistant stainless steel.

Consult Local Sales Representative for safety head assemblies rated above 60,000 psi (4137 bar).

**ASME Safety Head Option is no longer available due to a change in code April 2016 that makes it impractical to manufacture.**



## Ordering Information:

To order an Parker Autoclave Engineers Universal Safety Head, use the catalog order number from table. ADD THE SIZE OF THE RUPTURE DISC YOU WANT AS A SUFFIX TO THE CATALOG NUMBER; SUCH AS CS6600-1/4A.

Then order desired rupture discs from rupture disc section. (This is important since the disc size determines which hold-down ring will be furnished with the safety head.) Please note: Plug is included.

Hold-Down Nut Torque Values					
Torque @ Minimum Pressure		Torque @ Maximum Pressure		Rupture Disc Size Inches	Hold-Down Ring Part Number
Ft. lb. (N.m)	psi (bar)	Ft. lb. (N.m)	psi (bar)		
20 (27.1)	5000 (345)	90 (122)	26,500 (1827)	3/16 Flat†	112A-0439
40 (54.2)	4000 (276)	90 (122)	10,000 (690)	1/2 Flat	1050-7434
20 (27.1)	4000 (276)	140 (189.8)	60,000 (4137)	1/4 Angle	108A-0439

† 3/16 flat seat disc cannot be used with safety head assemblies SS6600, SS8600, 40CS9600 and CSX9600. Torque values for intermediate pressures may be linearly interpolated. Use minimum torque value for pressures lower than those shown.

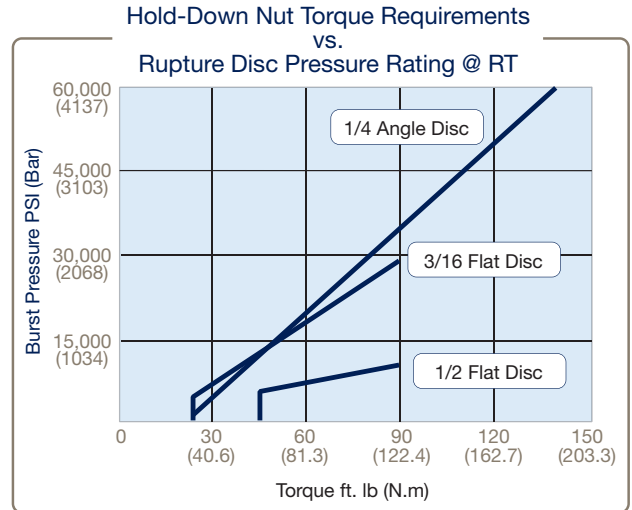

### 1/4 Angle Disc illustrated in Safety Head

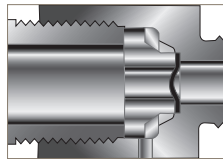
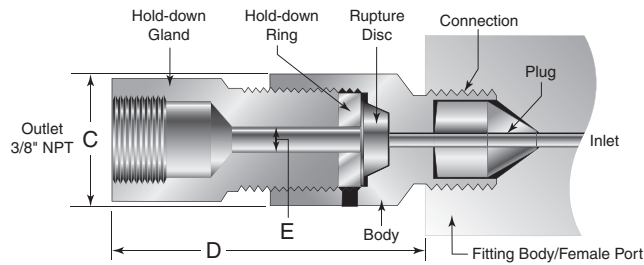

3/16 Flat Rupture Disc

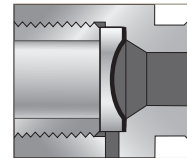

1/2 Flat Rupture Disc

Catalog Number (without Disc)	Body Part Number	Plug Part Number	Hold-Down Gland Part Number	Fits Connection Type	Fitting Pressure Rating psi (bar)	Body Torque Ft. lb. (N.m)	Plug Orifice inches (mm)	Body Orifice inches (mm)	Rupture Disc Size - inches (mm)			Dimensions Inches (mm)	
									3/16F Port E*	1/4A Port E*	1/2F Port E*	C	D

## Low Pressure

SS2600	2010-7035	101A-0434	3/16, 1/2 Flat 1040-7434	W125 (1/8" LP)	15,000 (1034)	15 (20.3)	0.094 (2.39)	0.125 (3.15)	0.188 (4.78)	0.25 (6.35)	0.50 (12.7)	1.00 (25.4)	2.13 (53.96)
SS4600	2020-7035	102A-0434		SW250 (1/4" LP)	15,000 (1034)	15 (20.3)	0.125 (3.18)	0.250 (6.35)	0.188 (4.78)	0.25 (6.35)	0.50 (12.7)	1.00 (25.4)	2.13 (53.96)
SS6600	2030-7035	103A-0434	1/4 Angle 1030-0241	SW375 (3/8" LP)	15,000 (1034)	15 (20.3)	0.250 (6.35)	0.375 (9.53)	NA	0.25 (6.35)	0.50 (12.7)	1.00 (25.4)	2.13 (53.96)
SS8600	2040-7035	104A-0434		SW500 (1/2" LP)	10,000 (690)	20 (22.1)	0.375 (9.53)	0.375 (9.53)	NA	0.25 (6.35)	0.50 (12.7)	1.00 (25.4)	2.13 (53.96)

Port E\* - Minimum disc blow-out diameter of hold down ring

Note: Interchangeable hold-down rings permit use of several different sizes and types of rupture disc in a single safety head.

Maximum pressure rating is based on the lowest rating of any component. Actual working pressure may be determined by tubing pressure rating, if lower. All dimensions for reference only and subject to change. For prompt service, Parker Autoclave Engineers stocks select products. Consult your local representative.

# Universal Safety Heads

Accessories - Pressures to 110,000 psi (7584 bar)

1/4 Angle Disc illustrated in Safety Head

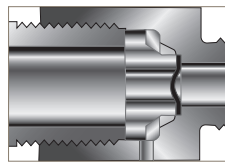
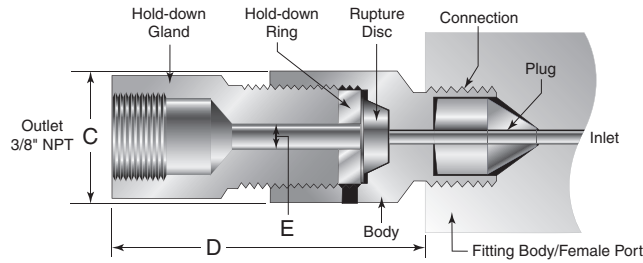

3/16 Flat Rupture Disc

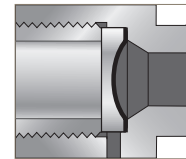

1/2 Flat Rupture Disc

Catalog Number (without Disc)	Body Part Number	Plug Part Number	Hold-Down Gland Part Number	Fits Connection Type	Pressure Rating psi (bar)	Body Torque Ft. lb. (N.m)	Plug Orifice inches (mm)	Body Orifice inches (mm)	Rupture Disc Size - inches (mm)			Dimensions Inches (mm)	
									3/16F Port E*	1/4A Port E*	1/2F Port E*	C	D

## Medium Pressure

CSX4600	101A-1731	2010-7823	3/16, 1/2 Flat 1040-7434	SF250CX (1/4" MP)	20,000 (1379)	15 (20.3)	0.094 (2.39)	0.141 (3.585)	0.188 (4.78)	0.25 (6.35)	0.50 (12.7)	1.00 (25.4)	2.19 (55.63)
CSX6600	102A-1731	2010-7844		SF375CX (3/8" MP)	20,000 (1379)	20 (27.1)	0.171 (4.34)	0.250 (6.35)	0.188 (4.78)	0.25 (6.35)	0.50 (12.7)	1.00 (25.4)	2.19 (55.63)
CSX9600	101A-0438	102A-0438	1/4 Angle 1030-0241	SF562CX (9/16" MP)	20,000 (1379)	30 (40.6)	0.312 (7.92)	0.375 (9.53)	NA	0.25 (6.35)	0.50 (12.7)	1.00 (25.4)	2.19 (55.63)

## High Pressure

CS4600	2010-7036	1030-4877	3/16, 1/2 Flat 1040-7434	F250C (1/4" HP)	60,000 (4137)	20 (27.1)	0.082 (2.08)	0.125 (3.18)	0.188 (4.78)	0.25 (6.35)	0.50 (12.7)	1.00 (25.4)	2.25 (57.15)
CS6600	2020-7036	1030-6096		F375C (3/8" HP)	60,000 (4137)	40 (54.2)	0.125 (3.18)	0.219 (5.56)	0.188 (4.78)	0.25 (6.35)	0.50 (12.7)	1.00 (25.4)	2.25 (57.15)
CS9600	2030-7036	1030-6097	1/4 Angle 1030-0241	F562C (9/16" HP)	60,000 (4137)	80 (108.5)	0.188 (4.78)	0.281 (7.13)	0.188 (4.78)	0.25 (6.35)	0.50 (12.7)	1.19 (30.23)	2.25 (57.15)
40CS9600	2030-7036	101C-7192		F562C40 (9/16" 40K)	40,000 (2758)	80 (108.5)	0.250 (6.35)	0.281 (7.13)	NA	0.25 (6.35)	0.50 (12.7)	1.19 (30.23)	2.25 (57.15)
100CS58B8	AE003595-01	101F-3358	108A-0439	F312C150 (5/16" UHP)	100,000 (6895)	250 (339)	0.093 (2.36)	0.093 (2.36)	NA	0.25 (6.35)	NA	2.25 (57.15)	4.13 (104.90)

## Pipe (NPT)

PS4600	101F-5292		1/4 Angle 1030-0241	1/4" NPT	15,000 (1034)			0.188 (4.78)	0.188 (4.78)	0.25 (6.35)	0.50 (12.7)	0.81 (20.6)	1.31 (33.3)
PS8600	101F-4342		1/2 Flat 1040-7434	1/2" NPT	10,000 (690)			0.312 (7.92)	0.188 (4.78)	0.25 (6.35)	0.50 (12.7)	0.81 (20.6)	1.31 (33.3)

Port E\* - Minimum disc blow-out diameter of hold down ring

Note: Interchangeable hold-down rings permit use of several different sizes and types of rupture disc in a single safety head.

Maximum pressure rating is based on the lowest rating of any component. Actual working pressure may be determined by tubing pressure rating, if lower. All dimensions for reference only and subject to change. For prompt service, Parker Autoclave Engineers stocks select products. Consult your local representative.

# Prebulged Rupture Discs

Pressures to 75,000 psi (5171 bar)

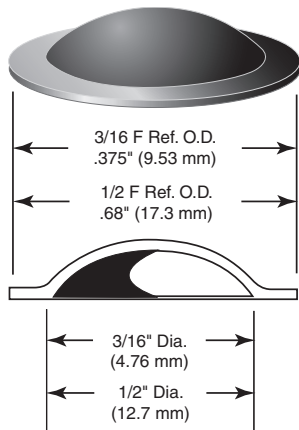

Flat Seat Rupture Disc

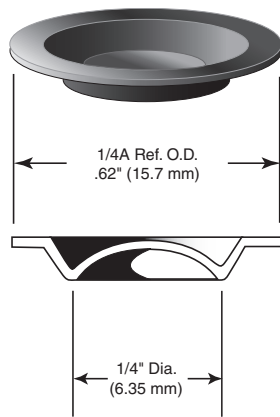

30° Angular Seat Rupture Disc

## Ordering Information:

Specify quantity, disc size, type, material and temperature.

- **Stock Disc(s):** Choose part number that corresponds to desired rupture rating which should be at least 110% of operating pressure. The burst rating tolerance is +/- 5% of the furnished tag rating. Discs are rated at 72°F (22°C).
- **Special Rupture Disc Order:** Special burst pressures can be ordered. The manufacturing tolerance of requested "Burst Pressure" will be +0%/-5%. For example, if a 20,000 psi disc is requested, the burst pressure of the supplied disc can be from 20,000 to 19,000 psi. This disc will have a "Burst Tolerance" of +/-5%. Based on the suppliers tolerances, the resultant disc could burst between 21,000 psi and 18,050 psi. Order number example **RD20000-5-1/4A**
- Minimum order of 6 discs required for Special Orders or for materials other than Inconel.

Note: Inconel disc normally available from stock.

Disc Material	Disc Size Seat Type	Rupture Pressure Standard available Range ± 5%	Maximum Temperature Rating
	inches	psi (bar)	°F (°C)
Hastelloy C	3/16 Flat	4,400 to 65,000 (303.4 to 4481.5)	1000 (538)
	1/4 Angle	3,300 to 70,000 (227.5 to 4826.3)	1000 (538)
	1/2 Flat	1,000 to 10,000 (68.9 to 690)	1000 (538)
Monel	3/16 Flat	2,650 to 20,000 (182.7 to 1378.9)	800 (427)
	1/4 Angle	2,000 to 40,000 (137.9 to 2757.9)	800 (427)
	1/2 Flat	1,000 to 7,500 (68.5 to 517.1)	800 (427)
Inconel 600 (Standard)	3/16 Flat	2,000 to 2,700 (13.8 to 1861.6)	900 (482)
	1/4 Angle	900 to 75,000 (62.1 to 5171)	900 (482)
	1/2 Flat	500 to 10,000 (34.5 to 690)	900 (482)
Type 316 Stainless Steel	3/16 Flat	1,750 to 20,000 (120.7 to 1378.9)	900 (482)
	1/4 Angle	1,250 to 60,000 (86.2 to 4136.8)	900 (482)
	1/2 Flat	700 to 10,000 (48.3 to 690)	900 (482)

PTFE coating available on one or both sides to increase minimum rupture rating.

CAUTION: High pressure-to-rupture ratios, severe pressure or temperature cycling, corrosion and metal fatigue affect disc life and rupture pressure. Frequent disc replacement may be desirable to avoid premature rupture.

All dimensions for reference only and subject to change.

For prompt service, Parker Autoclave Engineers stocks select products. Consult your local representative.

# Rupture Disc Stock Part Listing

## Accessories - 3/16 Flat Disc

Part Number	Description	Material	Pressure Range (psi)	Pressure Range (bar)
P-7003	3/16F DISC	Inconel	1908-2120	131-146
P-7674	3/16F DISC	Inconel	2194-2438	151-168
P-7005	3/16F DISC	Inconel	2862-3180	197-219
P-7007	3/16F DISC	Inconel	3148-3498	217-241
P-7009	3/16F DISC	Inconel	3816-4240	263-292
P-7011	3/16F DISC	Inconel	4330-4700	292-324
P-7013	3/16F DISC	Inconel	4770-5300	329-365
P-7015	3/16F DISC	Inconel	5056-5618	348-387
P-7017	3/16F DISC	Inconel	5247-5830	362-402
P-7018	3/16F DISC	Inconel	5533-6148	382-424
P-7019	3/16F DISC	Inconel	5629-6254	388-431
P-7020	3/16F DISC	Inconel	5724-6360	395-439
P-7021	3/16F DISC	Inconel	5915-6572	408-453
P-7022	3/16F DISC	Inconel	6010-6678	414-460
P-7024	3/16F DISC	Inconel	6201-6890	428-475
P-7026	3/16F DISC	Inconel	6678-7420	461-512
P-7028	3/16F DISC	Inconel	7155-7950	493-548
P-7030	3/16F DISC	Inconel	7632-8480	527-585
P-7032	3/16F DISC	Inconel	8109-9010	559-621
P-7034	3/16F DISC	Inconel	8586-9540	592-658
P-7040	3/16F DISC	Inconel	10017-11130	690-767
P-7044	3/16F DISC	Inconel	10971-12190	756-840
P-7046	3/16F DISC	Inconel	11448-12720	789-877
P-7048	3/16F DISC	Inconel	11925-13250	823-914
P-7050	3/16F DISC	Inconel	12402-13780	855-950
P-7052	3/16F DISC	Inconel	12879-14310	888-987
P-7054	3/16F DISC	Inconel	13356-14840	921-1023
P-7056	3/16F DISC	Inconel	13833-15370	954-1060
P-7058	3/16F DISC	Inconel	14310-15900	986-1096
P-7060	3/16F DISC	Inconel	14787-16430	1020-1133
P-7062	3/16F DISC	Inconel	15264-16960	1052-1169
P-7064	3/16F DISC	Inconel	15741-17490	1085-1206
P-7068	3/16F DISC	Inconel	16695-18550	1151-1279
P-7072	3/16F DISC	Inconel	17649-19610	1217-1352
P-7074	3/16F DISC	Inconel	18126-20140	1250-1389
P-7080	3/16F DISC	Inconel	19557-21730	1348-1498
P-7082	3/16F DISC	Inconel	20034-22260	1382-1535
P-7084	3/16F DISC	Inconel	20511-22790	1414-1571
P-7086	3/16F DISC	Inconel	20988-23320	1447-1608
P-7088	3/16F DISC	Inconel	21465-23850	1480-1644
P-7094	3/16F DISC	Inconel	22896-25440	1579-1754
P-7096	3/16F DISC	Inconel	23850-26500	1644-1827
P-7098	3/16F DISC	Inconel	24327-27030	1676-1864

# Rupture Disc Stock Part Listing

## Accessories - 1/4 Angle Disc

Part Number	Description	Material	Pressure Range (psi)	Pressure Range (bar)
P-7301	1/4A DISC	Inconel	954-1060	66-73
P-7303	1/4A DISC	Inconel	1145-1272	79-88
P-7305	1/4A DISC	Inconel	1431-1590	99-110
P-7307	1/4A DISC	Inconel	1670-1855	115-128
P-7309	1/4A DISC	Inconel	1908-2120	131-146
P-7311	1/4A DISC	Inconel	2385-2650	165-183
P-7313	1/4A DISC	Inconel	2862-3180	197-219
P-7315	1/4A DISC	Inconel	3339-3710	230-256
P-7317	1/4A DISC	Inconel	3816-4240	263-292
P-7319	1/4A DISC	Inconel	4293-4770	296-365
P-7321	1/4A DISC	Inconel	4773-5300	329-365
P-7323	1/4A DISC	Inconel	5247-5830	362-402
P-7325	1/4A DISC	Inconel	5724-6360	394-438
P-7327	1/4A DISC	Inconel	6201-6890	428-475
P-7329	1/4A DISC	Inconel	6678-7420	461-512
P-7331	1/4A DISC	Inconel	7155-7950	493-548
P-7333	1/4A DISC	Inconel	7632-8480	527-585
P-7335	1/4A DISC	Inconel	8109-9010	559-621
P-7337	1/4A DISC	Inconel	8586-9540	592-658
P-7339	1/4A DISC	Inconel	9063-10070	625-694
P-7341	1/4A DISC	Inconel	9540-10600	658-731
P-7343	1/4A DISC	Inconel	10017-11130	724-804
P-7345	1/4A DISC	Inconel	10494-11660	724-804
P-7347	1/4A DISC	Inconel	10971-12190	757-841
P-7349	1/4A DISC	Inconel	11448-12720	789-877
P-7351	1/4A DISC	Inconel	11925-13250	823-914
P-7353	1/4A DISC	Inconel	12402-13780	855-950
P-7355	1/4A DISC	Inconel	12879-14310	888-987
P-7357	1/4A DISC	Inconel	13356-14840	921-1023
P-7361	1/4A DISC	Inconel	14310-15900	986-1096
P-7363	1/4A DISC	Inconel	14787-16430	1020-1133
P-7365	1/4A DISC	Inconel	15264-16960	1052-1169
P-7367	1/4A DISC	Inconel	15741-17490	1085-1206
P-7369	1/4A DISC	Inconel	16218-18020	1118-1242
P-7371	1/4A DISC	Inconel	16695-18550	1151-1279
P-7373	1/4A DISC	Inconel	17172-19080	1184-1315
P-7375	1/4A DISC	Inconel	17649-19610	1217-1352
P-7377	1/4A DISC	Inconel	18603-20670	1283-1425
P-7379	1/4A DISC	Inconel	19080-21200	1316-1462
P-7381	1/4A DISC	Inconel	19557-21730	1348-1498
P-7382	1/4A DISC	Inconel	19800-22000	1365-1517
P-7383	1/4A DISC	Inconel	21465-23850	1480-1644
P-7385	1/4A DISC	Inconel	23850-26500	1644-1827

# Rupture Disc Stock Part Listing

## Accessories - 1/4 Angle Disc - continued

Part Number	Description	Material	Pressure Range (psi)	Pressure Range (bar)
P-7387	1/4A DISC	Inconel	24804-27560	1710-1900
P-7389	1/4A DISC	Inconel	25758-28620	1776-1973
P-7391	1/4A DISC	Inconel	26712-29680	1841-2046
P-7393	1/4A DISC	Inconel	28620-31800	1973-2192
P-7395	1/4A DISC	Inconel	29574-32860	2039-2266
P-7397	1/4A DISC	Inconel	31005-34450	2138-2375
P-7399	1/4A DISC	Inconel	33390-37100	2302-2558
P-7401	1/4A DISC	Inconel	35775-39750	2467-2741
P-7403	1/4A DISC	Inconel	38160-42400	2631-2923
P-7405	1/4A DISC	Inconel	40545-45050	2795-3106
P-7407	1/4A DISC	Inconel	42930-47700	2960-3289
P-7409	1/4A DISC	Inconel	47700-53000	3289-3654
P-7411	1/4A DISC	Inconel	52470-58300	3618-4020
P-7413	1/4A DISC	Inconel	57240-63600	3618-4020
P-7415	1/4A DISC	Inconel	59400-66000	4095-4550
P-7417	1/4A DISC	Inconel	64872-72080	4473-4970
P-7419	1/4A DISC	Inconel	67734-75260	4670-5189

# Rupture Disc Stock Part Listing

## Accessories - 1/2 Flat Disc

Part Number	Description	Material	Pressure Range (psi)	Pressure Range (bar)
P-7601	1/2F DISC	Inconel	477-530	33-37
P-7603	1/2F DISC	Inconel	668-742	46-51
P-7605	1/2F DISC	Inconel	716-795	50-55
P-7607	1/2F DISC	Inconel	859-954	66-73
P-7609	1/2F DISC	Inconel	954-1060	68-75
P-7610	1/2F DISC	Inconel	990-1100	68-76
P-7611	1/2F DISC	Inconel	1145-1272	79-88
P-7613	1/2F DISC	Inconel	1191-1323	82-91
P-7615	1/2F DISC	Inconel	1336-1484	92-102
P-7617	1/2F DISC	Inconel	1431-1590	99-110
P-7619	1/2F DISC	Inconel	1526-1696	105-117
P-7621	1/2F DISC	Inconel	1670-1855	115-128
P-7623	1/2F DISC	Inconel	1717-1908	119-132
P-7625	1/2F DISC	Inconel	1908-2120	131-146
P-7627	1/2F DISC	Inconel	2147-2385	148-164
P-7629	1/2F DISC	Inconel	2194-2438	151-168
P-7631	1/2F DISC	Inconel	2385-2650	165-183
P-7633	1/2F DISC	Inconel	2576-2862	177-197
P-7635	1/2F DISC	Inconel	2671-2968	184-204
P-7637	1/2F DISC	Inconel	2862-3180	197-219
P-7639	1/2F DISC	Inconel	3053-3392	211-234
P-7641	1/2F DISC	Inconel	3339-3710	230-256
P-7643	1/2F DISC	Inconel	3530-3922	243-270
P-7645	1/2F DISC	Inconel	3578-3975	247-274
P-7647	1/2F DISC	Inconel	3816-4240	263-292
P-7649	1/2F DISC	Inconel	4293-4770	296-329
P-7651	1/2F DISC	Inconel	4388-4876	302-336
P-7653	1/2F DISC	Inconel	4770-5300	329-365
P-7655	1/2F DISC	Inconel	5247-5830	362-402
P-7657	1/2F DISC	Inconel	5533-6148	382-424
P-7659	1/2F DISC	Inconel	5724-6360	394-438
P-7661	1/2F DISC	Inconel	6201-6890	428-475
P-7663	1/2F DISC	Inconel	6678-7420	461-512
P-7665	1/2F DISC	Inconel	7155-7950	493-548
P-7667	1/2F DISC	Inconel	7632-8480	527-585
P-7669	1/2F DISC	Inconel	8109-9010	559-621
P-7671	1/2F DISC	Inconel	8586-9540	592-658
P-7673	1/2F DISC	Inconel	9540-10600	658-731

# Pressure Gauges

P-Style High Accuracy Gauges to 80,000 psi (5115 bar)



## Gauges:

Pressure gauges are offered for use in low, medium and high pressure systems to pressures up to 80,000 psi (5515 bar). Adapters are available.

## Material and Features (Low, Medium and High Pressure System Gauges):

- Gauges are Dual Scale, Single Color, PSI and BAR graduations
- ASME Grade 2A, +/- .5% full scale accuracy
- Connection: Female F250C 1/4" High Pressure. **-CG** suffix required to include Collar & Gland
- Acrylic dial cover/solid front aluminum alloy case
- 316 Stainless steel Bourdon tubes\*\*
- Gauges available with bottom entry as standard or back (**-B** suffix) entry connection
- Precision stainless steel movement for accuracy and resistance to atmospheric corrosion
- Pointer zero adjustment located on front of gauge behind dial cover for convenience
- Standard gauges are rated from -20°F to 250°F (-30°C to 121°C) dry, 20°F to 200°C (-7°C to 93°C) Liquid Filled
- Calibration report available on special orders only
- Gauges glycerin filled upon request (**-LF** suffix)

## Instrument Quality Gauges:

**Flush panel mounting** - Panel mounting kits are stocked to permit flush panel mounting of any instrument quality gauge.

To order gauge panel mount kit:

- P-8559 4.5" Flush mount
- P-8560 6.0" Flush mount

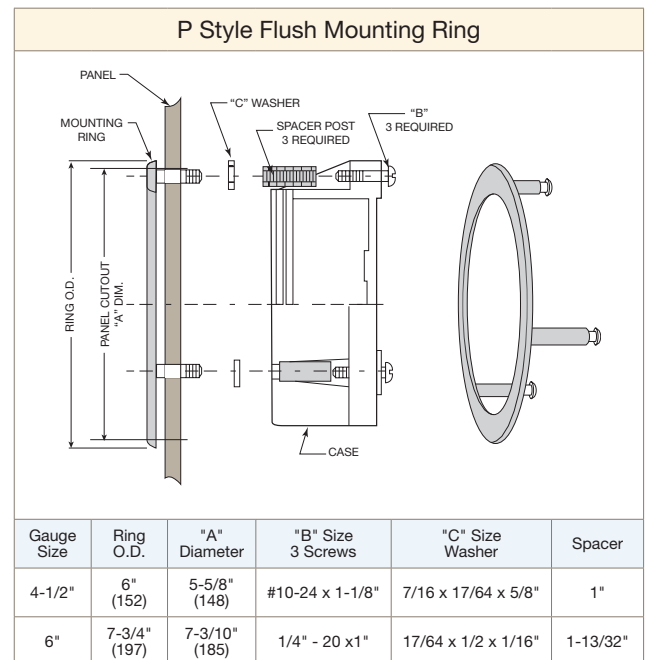





Note: Gauge connections are female 1/4" (F250C) High Pressure coned-and-threaded connection. Furnished with collar and gland (-CG suffix).

**Optional electrical contact face** - Available for all instrument quality gauges. With adjustable low and high electrical contacts, this option permits gauges to provide pressure control for automatic or remote operation, or for fail-safe set points.

\*\*Bourdon tube material for 0-30,000 psi gauge is K Monel. Bourdon tube material for 0-50,000 psi and 0-80,000 psi gauge is Inconel 718.

P-Style Bottom Connection Gauges			
Catalog Number	Pressure Range psi (bar)	Minor Interval Value psi (bar)	Dial Diameter inches (mm)
P-0499-CG	0-1,000 (0-70)	10 (1)	4-1/2 (114)
P-0479-CG	0-1,500 (0-100)	20 (1)	4-1/2 (114)
P-0480-CG	0-3,000 (0-200)	50 (2)	4-1/2 (114)
P-0481-CG	0-5,000 (0-350)	50 (5)	4-1/2 (114)
P-0482-CG	0-10,000 (0-700)	100 (5)	4-1/2 (114)
P-0483-CG	0-15,000 (0-1000)	100 (10)	4-1/2 (114)
P-0487-CG	0-20,000 (0-1400)	200 (20)	4-1/2 (114)
P-0488-CG**	0-30,000 (0-2000)	250 (20)	6 (152)
P-0489-CG**	0-50,000 (0-3500)	500 (20)	6 (152)
P-0490-CG**	0-80,000 (0-5500)	1,000 (50)	6 (152)

P-Style Back Connection Gauges			
Catalog Number	Pressure Range psi (bar)	Minor Interval Value psi (bar)	Dial Diameter inches (mm)
P-0482B-CG	0-10,000 (0-700)	100 (5)	4-1/2 (114)
P-0483B-CG	0-15,000 (0-1000)	100 (10)	4-1/2 (114)
P-0487B-CG	0-20,000 (0-1400)	200 (20)	4-1/2 (114)
P-0488B-CG**	0-30,000 (0-2000)	200 (20)	6 (152)
P-0489B-CG**	0-50,000 (0-3500)	500 (25)	6 (152)

Optional Electrical Contact Face	
Catalog Number	Fits Gauge Dial Diameter inches (mm)
P-0713	4-1/2 (114)
P-0714	6 (152)

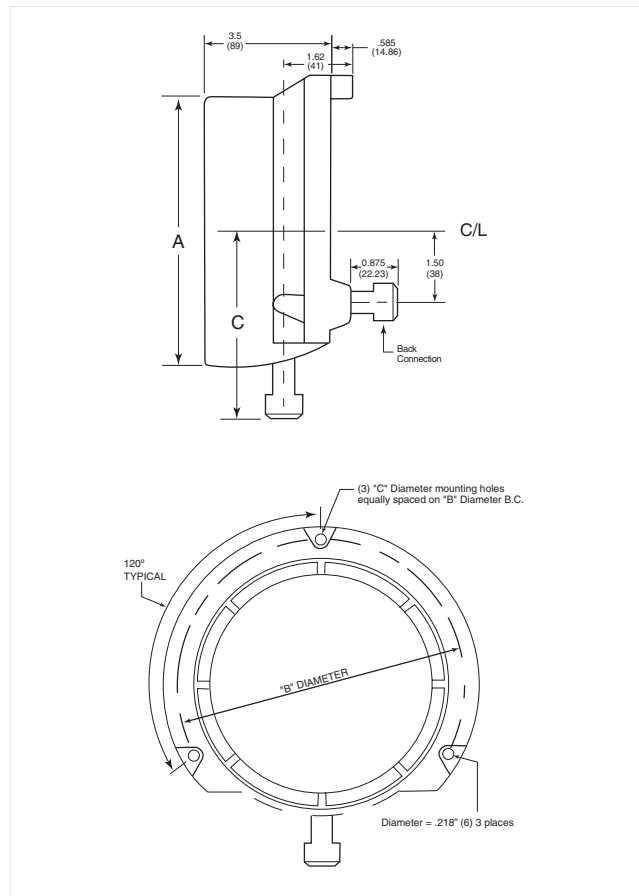

Panel Mount Layout			
Gauge Size inches (mm)	"A" Cutout inches (mm)	"B" inches (mm)	"C" inches (mm)
4-1/2 (114)	4-7/8 (124)	5-3/8 (137)	3-15/16 (100)
6 (152)	6-5/8 (162)	7 (178)	4-1/2 (114)

# Pressure Gauges

H-Style Sour Service Stainless Steel Gauges - Pressures to 30,000 psi (2068 bar)

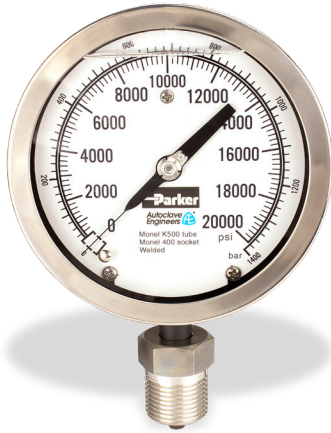

## Overview:

Parker Autoclave Engineers H Series Pressure Gauges are suitable for use where ambient corrosion is a major concern and are NACE MR01-75 2002 compliant. Its stainless steel case and ring offer good appearance and excellent resistance to chemical, weather and corrosion attack. The bourdon tube is made from K-Monel providing durability and performance when used with aggressive process media.

These gauges are available dry or liquid filled (-**LF** suffix).

Factory Calibrated			
Catalog Number	Pressure psi (bar)	Minor Interval Value psi (bar)	Dial Diameter Inches (mm)
H-0380	0-5000 (350)	50 (5)	4-1/2 (114)
H-0336	0-10,000 (700)	100 (5)	4-1/2 (114)
H-0071	0-15,000 (1000)	100 (10)	4-1/2 (114)
H-0304	0-20,000 (1400)	200 (20)	4-1/2 (114)
H-0360	0-30,000 (2000)	250 (20)	4-1/2 (114)

\* Glycerine is standard liquid filled for "LF" option

## Material and Features:

- Gauges are Dual Scale, Single Color, PSI and BAR graduations.
- ASME Grade 1A, +/-1% of span accuracy
- Temperature Range (Process), -20°F to 250°F (-29°C to 121°C) - Dry, 20°F to 150°F (-7°C to 93°C) - Liquid Filled (Glycerin)
- 304 stainless steel case and ring, glass window
- K-Monel Bourdon tube and socket
- Connection: Male M562C 9/16" High Pressure Cone & Thread (API Type III) All gauges furnished with SOG 316 SS collar and gland as standard
- Precision Teflon® -coated, 400 stainless steel movement for accuracy and resistance to atmospheric corrosion.
- Pointer zero adjustment located on front of gauge behind dial cover for convenience.
- Gauges can be liquid filled (Add - **LF** to Catalog number)\*
- Gauges are NACE MR0175-2002 compliant
- NIST Calibration reports available on special orders only

## H-Style Dimensions

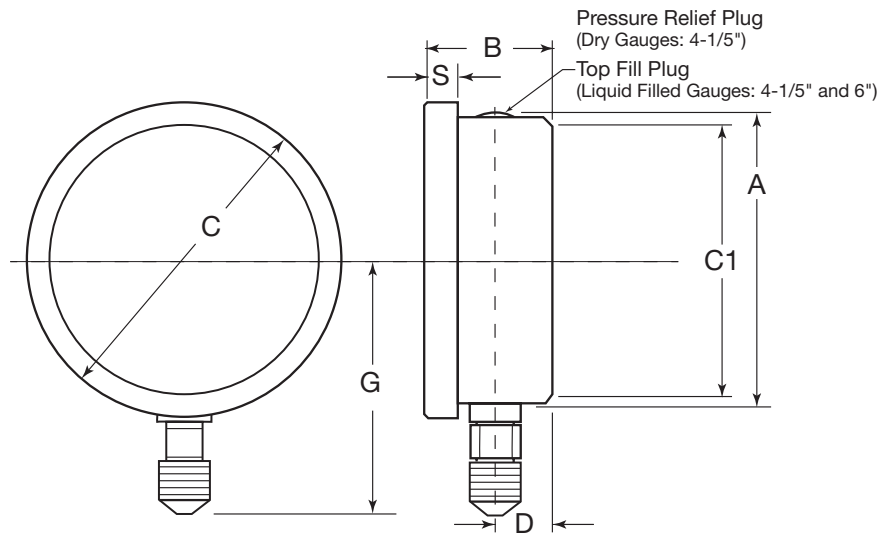

Gauge Size	A	B	C	C1	D	G	S	Weight	
								Dry	LF
4-1/2" (100)	4-23/32 (120)	2-1/16" (52)	5-3/32" (129)	6-1/4" (159)	15/16" (24)	3-15/16" (100)	15/32" (12)	1.75# .79kg	2.40# 1.1kg
6" (160)	6-5/16" (160)	2" (51)	6-21/32" (169)	7-41/64" (194)	27/32" (22)	4-13/16" (122)	13/32" (10)	2.25# 1kg	4.12# 1.85kg

# Gauge/Instrument Snubber

Accessories - Pressures to 100,000 psi (6895 bar)

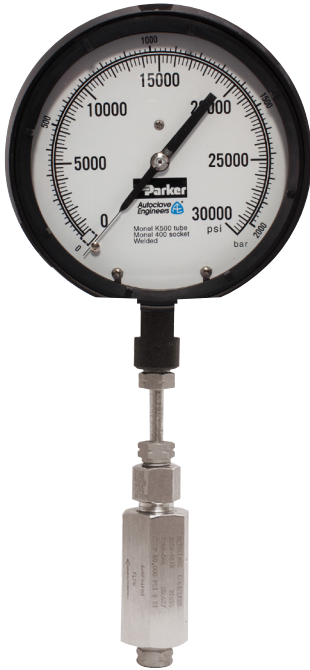

## Overview:

Parker Autoclave Engineers Pressure Snubbers provide protection to gauges and instrumentation from pressure surges, pulsation and shock. The unique snubber design provides superior instrument protection while not compromising instrument accuracy or reaction time. This is accomplished by the use of existing technology from our excess flow check valve with additional design features.

When sudden flow is experienced, the poppet will rise, blocking the pressure surge and a small bleed hole in the poppet will allow pressure to slowly equalize. When the pressure is equalized, the poppet will then drop allowing normal flow to the gauge. A 5 micron filter is used to prevent the hole in the plug from becoming plugged. **The snubber must be mounted in the vertical position as indicated on the unit.**

Snubbers are offered in CW316SS as standard, with either male, female or male/female connections in 1/4" and 3/8" sizes. Optional materials available upon request.

Standard O-ring is FKM rated 400°F (204°C) maximum.

## Ordering Guide:

For complete information on available gauge snubber types and additional options, contact your Sales Representative.

Building a Part Number: *Example: SNBFH4FH4*

Example Part Number:	SNB	F	H4	F	H4	-	155*
Ordering Parameters/Options:	Gauge Snubber	Inlet Connection Type	Inlet Connection Size	Outlet Connection Type	Outlet Connection Size		Material*
Table Reference: (see below)	A	B	C	D	E		F

### A - Gauge Snubber

SNB	Gauge Snubber
100SNB	100,00 psi (6895) Gauge Snubber*

### B - Inlet Connection Type

M	Male
F	Female

### C - Inlet Connection Size

M4	1/4" Medium Pressure Connection - SF250CX
M6	3/8" Medium Pressure Connection - SF375CX
H4	1/4" High Pressure Connection - F250C (F250C100*)
H6	3/8" High Pressure Connection - F375C (F375C100*)

### D - Outlet Connection Type

M	Male
F	Female

### E - Outlet Connection Size

M4	1/4" Medium Pressure Connection - SF250CX
M6	3/8" Medium Pressure Connection - SF375CX
H4	1/4" High Pressure Connection - F250C (F250C100*)
H6	3/8" High Pressure Connection - F375C (F375C100*)

### F - Material\*

155	15-5PH Stainless Steel (Required for 100SNB)
-----	--

\* Denotes high pressure 100,000 psi (6895 bar) gauge snubber parameter only. See next page for available models

# Gauge /Instrumentation Snubbers Dimensions

Catalog Number	Pressure Rating psi (bar)*	Connection Types	Dimensions - inches (mm)						
			A	B	C	D Hex	Body (Hex)	Cover Gland (Hex)	Figure Reference
SNBFM4FM4	20,000 (1379)	SF250CX by SF250CX	2.77 (70.36)	2.38 (60.45)	0.38 (9.65)	1/2"	13/16"	13/16"	1
SNBFH4MH4	60,000 (4137)	F250C by M250C	4.05 (102.87)	2.50 (63.50)	0.50 (12.70)	5/8"	1-3/16"	1"	2
SNBMH6MH4	60,000 (4137)	M375C by M250C	3.68 (93.47)	2.13 (54.10)	1.50 (38.10)	3/4"	1-3/16"	1"	3
SNBFH4FH4	60,000 (4137)	F250C by F250C	3.36 (85.34)	2.50 (63.50)	0.50 (12.70)	5/8"	1-3/16"	13/16"	1
FH6FH4	60,000 (4137)	F375 by F250C	3.61 (91.69)	2.75 (69.85)	0.52 (13.21)	5/8"	1-3/16"	13/16"	1
SNBFH6FH6	60,000 (4137)	F375C by F375C	3.81 (96.77)	2.75 (69.85)	0.52 (13.21)	3/4"	1"	1"	1
100SNBFH6FH6-155	100,000 (6895)	F375C100 by F375C100	4.65 (118.11)	3.50 (88.90)	0.52 (13.21)	3/4"	1-3/4"	1-3/8"	1

## Gauge /Instrumentation Snubber

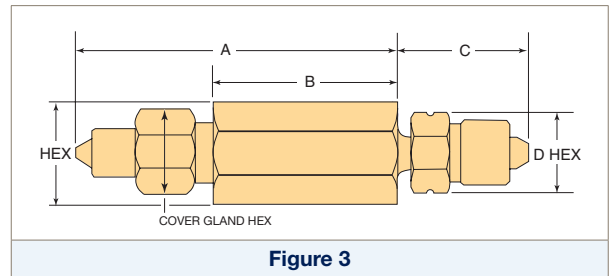
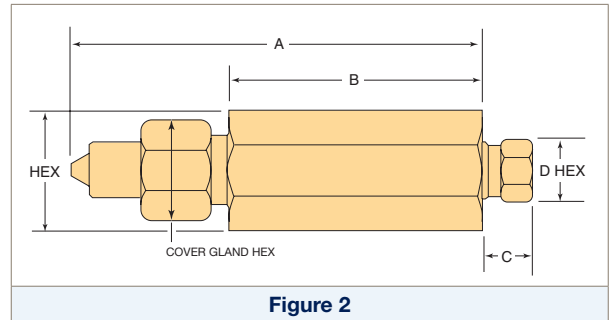
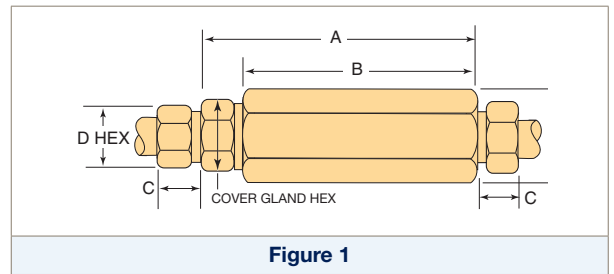
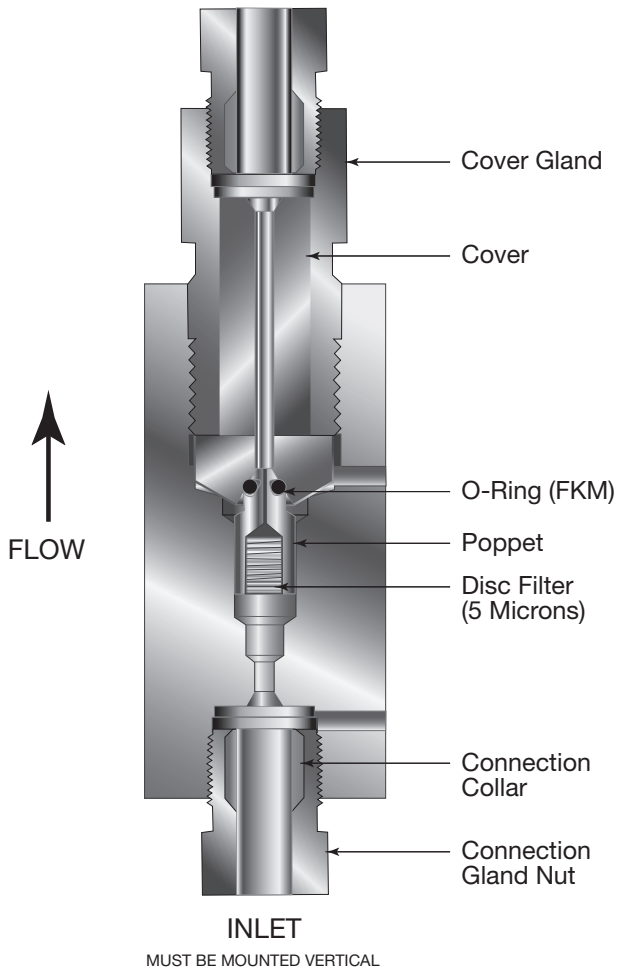

\*\* Across flats. Diameter 2.00

Catalog Number	Cover Torque (ft-lbs)	Poppet O-Ring	Filter
SNBFM4FM4	40	P-1655	P-1028
SNBFH4MH4	110	P-1768	90455
SNBMH6MH4	110	P-1655	P-1749
SNBFH4FH4	110	P-1655	P-1749
FH6FH4	110	P-1768	P-1749
SNBFH6FH6	110	P-1655	90455
100SNBFH6FH6-155	240	N/A	90455



# Parker's Motion & Control Technologies

At Parker, we're guided by a relentless drive to help our customers become more productive and achieve higher levels of profitability by engineering the best systems for their requirements. It means looking at customer applications from many angles to find new ways to create value. Whatever the motion and control technology need, Parker has the experience, breadth of product and global reach to consistently deliver. No company knows more about motion and control technology than Parker. For further information call 1-800-C-Parker.

MARKET	KEY MARKETS	KEY PRODUCTS		
 <b>AEROSPACE</b>	Aircraft Engines Commercial Commerical Transports Military Aircraft Regional Transports	Business and General Aviation Land-Based Weapons Systems Missiles and Launch Vehicles Unmanned Aerial Vehicles	Flight Control Systems & Components Fluid Conveyance Systems Fluid Metering Delivery & Atomization Devices Fuel Systems & Components	Hydraulic Systems & Components Inert Nitrogen Generating Systems Pneumatic Systems & Components Wheels & Brakes
 <b>CLIMATE CONTROL</b>	Agriculture Food, Beverage and Dairy Precision Cooling Transportation	Air Conditioning Life Sciences & Medical Processing	Co2 Controls Electronic Controllers Filter Driers Hand Shut-Off Valves Hose & Fittings	Pressure Regulating Valves Refrigerant Distributors Safety Relief Valves Solenoid Valves Thermostatic Expansion Valves
 <b>ELECTRO-MECHANICAL</b>	Aerospace Life Science & Medical Packaging Machinery Plastics Machinery & Converting Semiconductor & Electronics Factory Automation	Machine Tools Paper Machinery Primary Metals Textile Wire & Cable	AC/DC Drives & Systems Electric Actuators, Gantry Robots & Slides Electrohydrostatic Actuation Systems Electromechanical Actuation Systems Human Machine Interface	Linear Motors Stepper Motors, Servo Motors Drives & Controls Structural Extrusions
 <b>FILTRATION</b>	Food & Beverage Life Sciences Mobile Equipment Power Generation Transportation	Industrial Machinery Marine Oil & Gas Process	Analytical Gas Generators Compressed Air & Gas Filters Condition Monitoring Engine Air, Fuel & Oil Filtration & Systems	Hydraulic, Lubrication & Coolant Filters Process, Chemical, Water Microfiltration Filters Nitrogen, Hydrogen & Zero Air Generators
 <b>FLUID and GAS HANDLING</b>	Aerospace Agriculture Bulk Chemical Handling Construction Machinery Food & Beverage Fuel & Gas Delivery	Industrial Machinery Mobile Oil & Gas Transportation Welding	Brass Fittings & Valves Diagnostic Equipment Fluid Conveyance Systems Industrial Hose	PTFE & PFA Hose, Tubing & Plastic Fittings Rubber & Thermoplastic Hose & Couplings Tube Fittings & Adapters Quick Disconnects
 <b>HYDRAULICS</b>	Aerospace Aerial lift Agriculture Construction Machinery Forestry	Industrial Machinery Mining Oil & Gas Power Generation & Energy Truck Hydraulics	Diagnostic Equipment Hydraulic Cylinders & Accumulators Hydraulic Motors & Pumps Hydraulic Systems Hydraulic Valves & Controls	Power Take-Offs Rubber & Thermoplastic Hose & Couplings Tube Fittings & Adapters Quick Disconnects
 <b>PNEUMATICS</b>	Aerospace Conveyor & Material Handling Factory Automation Life Science & Medical	Machine Tools Packaging Machinery Transportation & Automotive	Air Preparation Brass Fittings & Valves Manifolds Pneumatic Accessories Pneumatic Actuators & Grippers Pneumatic Valves & Controls	Quick Disconnects Rotary Actuators Rubber & Thermoplastic Hose & Couplings Structural Extrusions Thermoplastic Tubing & Fittings Vacuum Generators, Cups & Sensors
 <b>PROCESS CONTROL</b>	Chemical & Refining Food, Beverage & Dairy Medical & Dental	Microelectronics Oil & Gas Power Generation	Analytical Sample Conditioning Products & Systems Fluoropolymer Chemical Delivery Fittings, Valves & Pumps High Purity Gas Delivery Fittings, & Valves & Regulators	Instrumentation Fittings, Valves Regulators Medium Pressure Fittings & Valves Process Control Manifolds
 <b>SEALING and SHIELDING</b>	Aerospace Chemical Processing Consumer Energy, Oil & Gas Fluid Power General Industrial	Information Technology Life Sciences Military Semiconductor Transportation	Dynamic Seals Elastomeric O-Rings Emi Shielding Extruded & Precision-Cut, Fabricated Elastomeric Seals	Homogeneous & Inserted Elastomeric Shapes High Temperature Metal Seals Metal & Plastic Retained Composite Seals Thermal Management

# Parker Worldwide

## North America

**USA** – Corporate, Cleveland, OH  
Tel: +1 256 896 3000

**USA** – IPD, Huntsville, AL  
Tel: +1 256 881 2040  
ipdcct@parker.com

**USA** – IPD, (Autoclave), Erie, PA  
Tel: +1 814 860 5700  
ipdaect@parker.com

**CA** – Canada, Grimsby, Ontario  
Tel: +1 905-945-2274  
ipd\_canada@parker.com

## South America

**AR** – Argentina, Buenos Aires  
Tel: +54 3327 44 4129  
falecom@parker.com

**BR** – Brazil, Diadema, SP  
Tel: +55 11 4360 6700  
falecom@parker.com

**CL** – Chile, Santiago  
Tel: +56 (0) 2 2303 9640  
falecom@parker.com

**MX** – Mexico, Toluca  
Tel: +52 722 275 4200  
contacto@parker.com

## Asia Pacific

**AU** – Australia, Dandenong  
Tel: +61 (0)2 9842 5150  
customer.service.au@parker.com

**CN** – China, Shanghai  
Tel: +86 21 2899 5000  
INGtechnical.china@parker.com

**HK** – Hong Kong  
Tel: +852 2428 8008

**IN** – India, Mumbai  
Tel: +91 22 6513 7081-85

**ID** – Indonesia, Tangerang  
Tel: +62 2977 7900  
parker.id@parker.com

**JP** – Japan, Tokyo  
Tel: +(81) 3 6365 4020  
infophj@parker.com

**KR** – South Korea, Seoul  
Tel: +82 2 559 0400  
parkerkr@parker.com

**MY** – Malaysia, Selangor  
Tel: +603 784 90 800  
parkermy@parker.com

**SG** – Singapore,  
Tel: +65 6887 6300  
parkerkg@parker.com

**TH** – Thailand, Bangkok  
Tel: +66 2 186 7000  
phthailand@parker.com

**TW** – Taiwan, Taipei  
Tel: +886 2 2298 8987  
enquiry.taiwan@parker.com

**VN** – Vietnam, Hochi Minh City  
Tel: +848 382 508 56  
parker\_viet@parker.com

## Europe, Middle East, Africa

**AE** – UAE, Dubai  
Tel: +971 4 812 7100  
parker.me@parker.com

**AT** – Austria, Wiener Neustadt  
Tel: +43 (0)2622 23501-0  
parker.austria@parker.com

**AT** – Eastern Europe, Wiener Neustadt  
Tel: +43 (0)2622 23501 900  
parker.easteurope@parker.com

**AZ** – Azerbaijan, Baku  
Tel: +994 50 2233 458  
parker.azerbaijan@parker.com

**BE/LU** – Belgium, Nivelles  
Tel: +32 (0)67 280 900  
parker.belgium@parker.com

**BG** – Bulgaria, Sofia  
Tel: +359 2 980 1344  
parker.bulgaria@parker.com

**BY** – Belarus, Minsk  
Tel: +48 (0)22 573 24 00  
parker.belarus@parker.com

**CH** – Switzerland, Etoy  
Tel: +41 (0) 21 821 87 00  
parker.switzerland@parker.com

**CZ** – Czech Republic, Klecany  
Tel: +420 284 083 111  
parker.czechrepublic@parker.com

**DE** – Germany, Kaarst  
Tel: +49 (0)2131 4016 0  
parker.germany@parker.com

**DK** – Denmark, Ballerup  
Tel: +45 43 56 04 00  
parker.denmark@parker.com

**ES** – Spain, Madrid  
Tel: +34 902 33 00 01  
parker.spain@parker.com

**FI** – Finland, Vantaa  
Tel: +358 (0)20 753 2500  
parker.finland@parker.com

**FR** – France, Contamine s/Arve  
Tel: +33 (0)4 50 25 80 25  
parker.france@parker.com

**GR** – Greece, Athens  
Tel: +30 210 933 6450  
parker.greece@parker.com

**HU** – Hungary, Budapest  
Tel: +36 223 885 470  
parker.hungary@parker.com

**IE** – Ireland, Dublin  
Tel: +353 (0)1 466 6370  
parker.ireland@parker.com

**IT** – Italy, Corsico (MI)  
Tel: +39 02 45 19 21  
parker.italy@parker.com

**KZ** – Kazakhstan, Almaty  
Tel: +7 7273 561 000  
parker.easteurope@parker.com

**NL** – The Netherlands, Oldenzaal  
Tel: +31 (0)541 585 000  
parker.nl@parker.com

**NO** – Norway, Stavanger  
Tel: +47 66 75 34 00  
parker.norway@parker.com

**PL** – Poland, Warsaw  
Tel: +48 (0)22 573 24 00  
parker.poland@parker.com

**PT** – Portugal, Leca da Palmeira  
Tel: +351 22 999 7360  
parker.portugal@parker.com

**RO** – Romania, Bucharest  
Tel: +40 21 252 1382  
parker.romania@parker.com

**RU** – Russia, Moscow  
Tel: +7 495 645-2156  
parker.russia@parker.com

**SE** – Sweden, Spånga  
Tel: +46 (0)8 59 79 50 00  
parker.sweden@parker.com

**SK** – Slovakia, Banská Bystrica  
Tel: +421 484 162 252  
parker.slovakia@parker.com

**SL** – Slovenia, Novo Mesto  
Tel: +386 7 337 6650  
parker.slovenia@parker.com

**TR** – Turkey, Istanbul  
Tel: +90 216 4997081  
parker.turkey@parker.com

**UA** – Ukraine, Kiev  
Tel: +48 (0)22 573 24 00  
parker.ukraine@parker.com

**UK** – United Kingdom, Warwick  
Tel: +44 (0)1926 317 878  
parker.uk@parker.com

**ZA** – South Africa, Kempton Park  
Tel: +27 (0)11 961 0700  
parker.southafrica@parker.com

### ! CAUTION !

Do not mix or interchange component parts or tubing with those of other manufacturers. Doing so is unsafe and will void warranty.

Parker Autoclave Engineers Valves, Fittings, and Tools are not designed to interface with common commercial instrument tubing and are designed to only connect with tubing manufactured to Parker Autoclave Engineers AES specifications. Failure to do so is unsafe and will void warranty.

### WARNING

**FAILURE, IMPROPER SELECTION OR IMPROPER USE OF THE PRODUCTS AND/OR SYSTEMS DESCRIBED HEREIN OR RELATED ITEMS CAN CAUSE DEATH, PERSONAL INJURY AND PROPERTY DAMAGE.**

This document and other information from Parker Hannifin Corporation, its subsidiaries and authorized distributors provide product and/or system options for further investigation by users having technical expertise. It is important that you analyze all aspects of your application and review the information concerning the product or system in the current product catalog. Due to the variety of operating conditions and applications for these products or systems, the user, through its own analysis and testing, is solely responsible for making the final selection of the products and systems and assuring that all performance, safety and warning requirements of the application are met. The products described herein, including without limitation, product features, specifications, designs, availability and pricing, are subject to change by Parker Hannifin Corporation and its subsidiaries at any time without notice.

### Offer of Sale

The items described in this document are available for sale by Parker Hannifin Corporation, its subsidiaries or its authorized distributors. Any sale contract entered by Parker will be governed by the provisions stated in Parker's standard terms and conditions of sale (copy available upon request).



Instrumentation Products Division  
Autoclave Engineers Operation  
8325 Hessinger Drive  
Erie, PA 16509-4679  
Tel: 814 860 5700  
Fax: 814 860 5811  
[www.autoclave.com](http://www.autoclave.com)  
[www.parker.com/ipd](http://www.parker.com/ipd)

Instrumentation Products Division  
Division Headquarters  
1005 A Cleaner Way  
Huntsville, AL 35805 USA  
Tel: 256 881 2040  
Fax: 256 881 5072

Parker Hannifin Manufacturing Ltd.  
Instrumentation Products Division,  
Europe  
Riverside Road  
Pottington Business Park  
Barnstaple, UK, EX31 1NP, UK  
Tel: 44 1271 313131  
Fax: 44 1271 373636